



REFERENCE INFORMATION NOTE;

GAZİ STEEL COLD STRIP MILL CHEMICAL TREATMENT PLANT

Water Circulation Rate : 1.450 m³/h (The Construction of Turnkey)

Capacity : 1.050.000 ton per year (SMS DMAG & SMS ZMAG, EBNER, POMINI, WALDRICH ZIEGEN, ATLAS COPCO)

Date : 2013/2014



Chemical Treatment Plant Excavation and Grobeton Pouring



Water Treatment Plant and Chemical Treatment Plant General Appearance



Water Treatment Plant and Chemical Treatment Plant General Appearance



Pump Section Embedded Plate



Water Basin Pump Section Pipes



Longitudinal Settling Basins



Longitudinal Settling Basin



Water Treatment Plant and Chemical Treatment Plant General Appearance



Chemical Treatment Plant Inlet Pipeline



Settling Basin Scrapper Bridges



Settling Basin Scrapper Bridges



Settling Basin Scrapper Bridges Installation



Settling Basin Scrapper Bridges Instalation



Acid and Alkaline Basin Transfer Pumps



DAF (Dissolved Air Flotation) and Polyelectrolyte Dosage Systems



DAF (Dissolved Air Flotation) and Polyelectrolyte Dosage Systems



Chemical Dosing Units



DAF (Dissolved Air Flotation) System For Removed to Rolling Mill Oil by Water



DAF (Dissolved Air Flotation) System For Removed to Rolling Mill Oil by Water



DAF (Dissolved Air Flotation) System For Removed to Rolling Mill Oil by Water



DAF (Dissolved Air Flotation) System For Removed to Rolling Mill Oil by Water



DAF (Dissolved Air Flotation) System For Removed to Rolling Mill Oil by Water

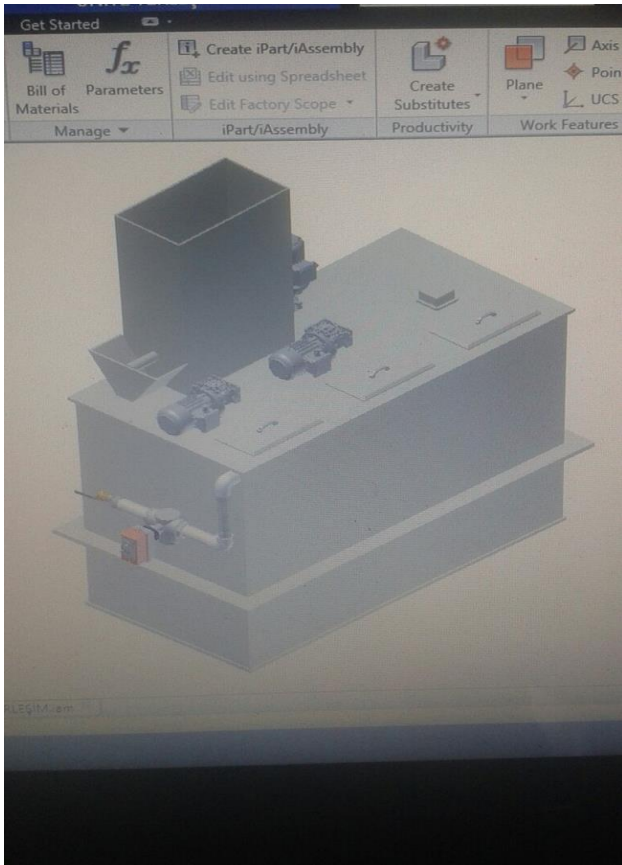

Polyelectrolyte Dosing Units



Polyelectrolyte Dosing Units



Longitudinal Settling Basin Sedimentation



Settling Basin Mixers and Oil Stripping Construction



Settling Basin Rapid Mixers



Settling Basin Slow Mixers



Water Treatment Plant and Chemical Treatment Plant General Appearance



Sludge Thickener Tanks



Sludge Thickener Mixers and Tank



Sludge Thickener Decanter and Tank

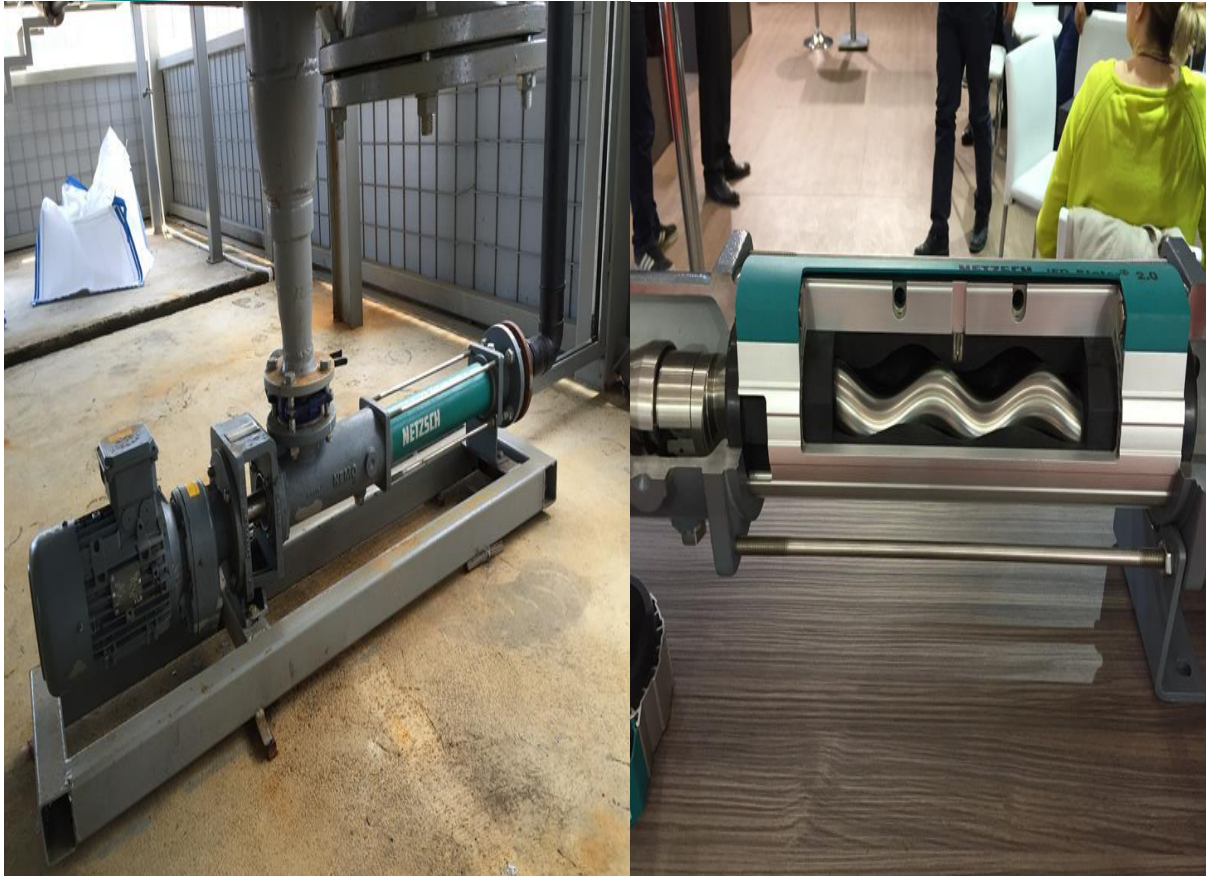

Sludge Pump and Pump Inside Detail



Bag of Dry Sludge



Chemical Treatment Plant Inside Hall



Chemical Treatment Plant General Appearance



Chemical Treatment Plant - Microbiological Treatment Basins



Blowers Air Bubbles - Microbiological Treatment Basins



Sand Filters



Sand Filters



Chemical Treatment Plant Treated Water Analys and Drain

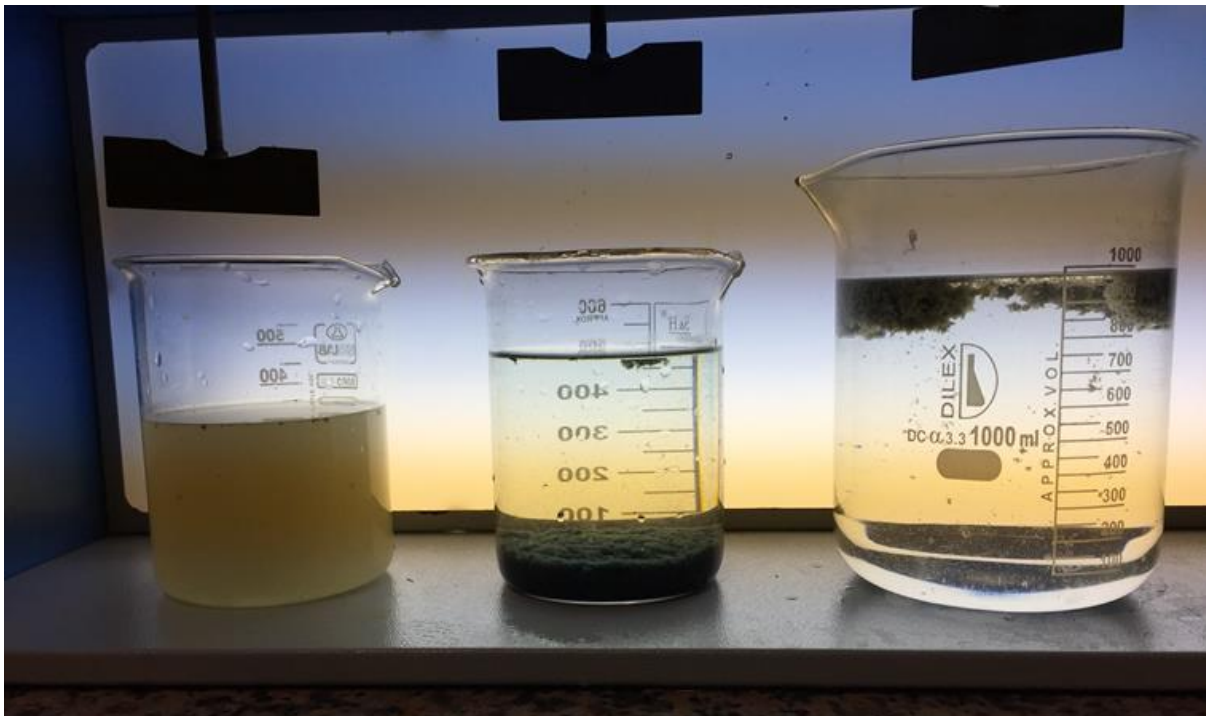

Sorting from left to right

- 1-Chemical Plant Inlet Water
- 2-Floculation and Sedimentation with Polyelectrolyte Dosage
- 3- Emulsion Breaker for Rolling Mill Oil



MCC Panel to Electric Cabinet



MCC Panel to Electric Cabinet



PLC Panel and Operation Pull Pit

Best Regards
Kemal BOLAT
Project Manager
www.etrasu.com